



ADANI BV5030

**CHECKPOINT X-RAY INSPECTION SYSTEM
FOR CARRY-ON BAGGAGE**



PT. PACIFIC AMAN GARDA

Phone +62 21 722 6039
Fax. +62 21 722 6041

www.pacificamangarda.com
info@pacificamangarda.com

The **ADANI BV 5030** is designed for visual inspection of different objects (baggage, mail, etc.) without opening them to reveal objects, materials and substances that are prohibited for import (export) or differ from declared content.

INTENDED USE

- Its use allows to effectively inspect parcels, small baggage and personal belongings to detect dangerous objects (including identification of substances by effective atomic number) and other prohibited items.
- The system allows identification of weapons, explosives (including plastic explosives), drugs, primers and dangerous objects, which are safety hazard.

CONFIGURATION

The basic functional components of the system are:

Device body:

- Frame
- Conveyor
- Inspection tunnel
- Distribution panel;

Digital X-ray image receiver:

- X-ray sensitive digital detector
- Electronic interface unit;

X-ray unit:

- X-ray generator (mono-block)
- Collimator (X-ray aperture);

Operator's workstation;

Set of control programs;

Set of spare parts, tools and accessories;

TIP software package;

Operational documentation;

Package.

Options:

- Exit / entry rollers;
- Operator's desk;
- Set of test objects.

TECHNICAL DATA

CONVEYOR BELT

Maximum distributed load on the conveyor belt, kg, max	160
Conveyor speed, m / s	0.22±0.03

DIGITAL X-RAY IMAGE RECEIVER

Receiver type	multiunit array	
Type of x-ray sensitive element	scintillator coated semiconductor photodiode	
Wire detectability (minimum diameter of copper wire/standard operating mode) mm	0.08 (40 AWG)	
Steel penetration, standard operation mode, mm	36	10*
Steel penetration, high penetration mode, mm	38	-

X-RAY UNIT

Anode voltage, kV		
- Standard operating mode	140	90*
- High penetration mode	160	-
Angle of radiation	60°	
Cooling system	oil cooling	
Anode type	stationary	

PHYSICAL PARAMETERS

Tunnel dimensions, mm	
- Width	520±3
- Height	320±5
Overall dimensions, not more than, mm	
- Width	735
- Height	1335
- Length	1250

* these values are applicable for the version with 90kV generator

SOFTWARE FEATURES

The purpose of the system software is to control the operation of the Scanner as well as to provide the opportunity to acquire, visualize and process digital X-ray images. To facilitate the work of the operator, a control panel is provided. The panel makes it possible to access all the software features.

GENERAL PURPOSE FUNCTIONS:

- Password-protected logon.

SELF-TESTING AND PERFORMANCE SUPPORT FUNCTIONS:

- Automatic self-testing;
- Displaying messages about operating status of the Scanner;
- Warming up the X-ray generator (the process can be started both manually and automatically).

HARDWARE CONTROL FUNCTIONS:

- Controlling the conveyor belt drive, the protective shutter's drive, the X-ray generator;
- Automatic changing of generator's operating modes depending on the scanner idle time;
- Acquiring data from the X-ray detector;
- Automatically calibrating the X-ray detector;
- Turning off the X-ray generator in case of emergency;
- Indicating X-ray on.

DIGITAL X-RAY IMAGE ACQUISITION, VISUALIZATION, AND PROCESSING FUNCTIONS:

- Acquiring images without additional algorithmic processing;
- Highlighting optically dense objects;
- Adjusting contrast of strongly absorbing objects;
- Inverting images;
- Performing gamma-correction of images;
- Optimizing the overall contrast: combination of edge enhancement and local contrast enhancement algorithms;
- Coloring images according to calculated values of atomic numbers of substances which compose objects under inspection;
- Coloring substances with atomic numbers from a selected range;
- Pseudocoloring objects with a possibility of selection of various palettes;
- Displaying organic objects with atomic numbers equal to 7, 8, and 9;
- Displaying substances according to a selected range of signal strength;
- Magnifying one out of nine predefined areas of an image;
- Zooming images up to 96x;
- Automatically highlighting suspicious objects (which can be related to drugs, explosives, or arms).

ADDITIONAL FUNCTIONS:

- Saving X-ray images to files;
- Storing a predefined number of images;
- Browsing the image archive;
- Copying images on external storage media (CD/DVD disks and flash-drives);
- Viewing and copying images from a local area network;
- Automatic preparing, filing and printing service reports;
- Controlling quality of operator's performance with the TIP program module;
- Counting inspected baggage.

- **GENERAL LAYOUT OF THE ADANI BV5030**

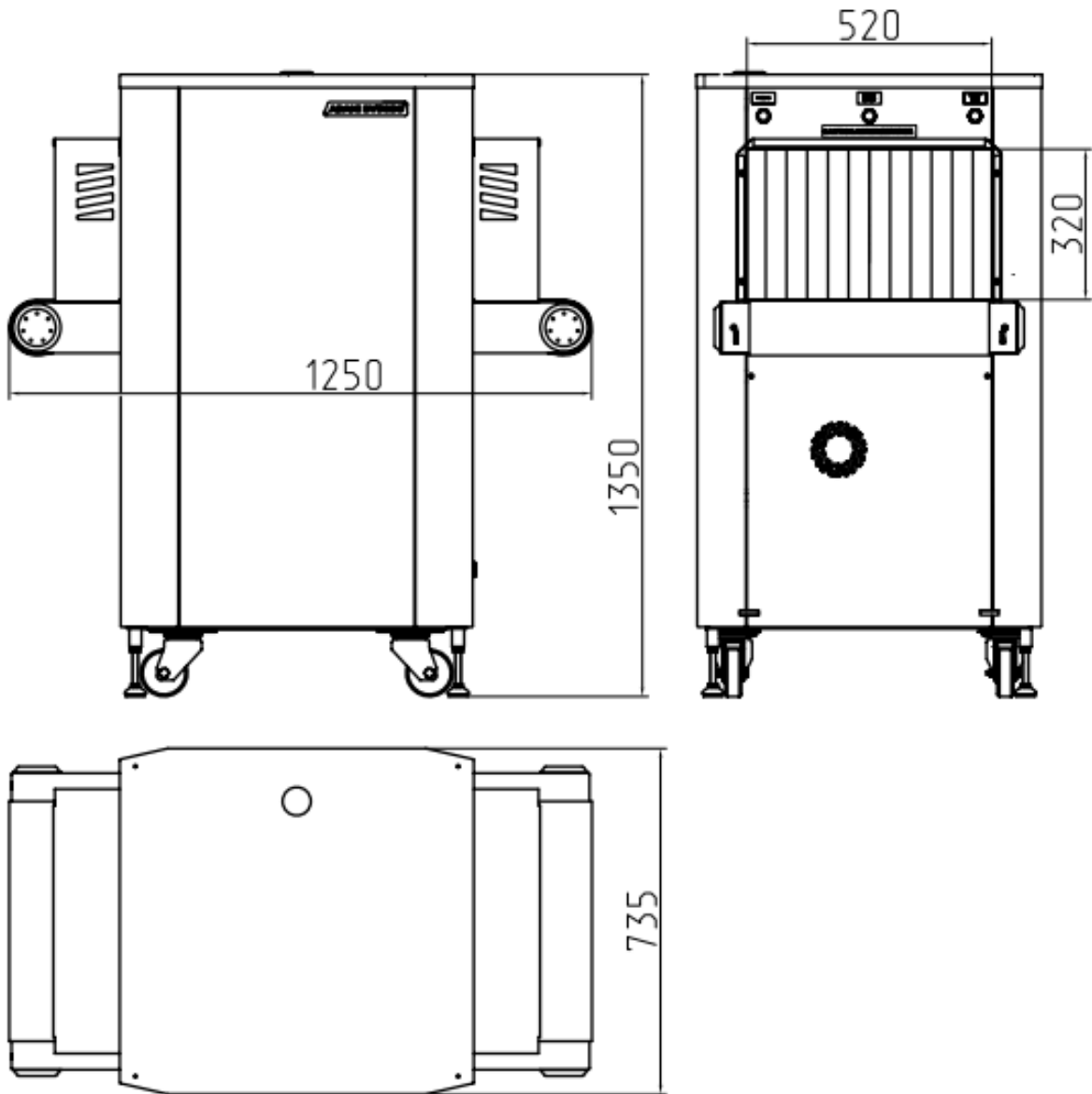

PT. PACIFIC AMAN GARDA

Phone +62 21 722 6039
Fax. +62 21 722 6041

www.pacificamangarda.com
info@pacificamangarda.com